

Technical Bulletin

GAS PRESSURE REGULATOR SERIES 274

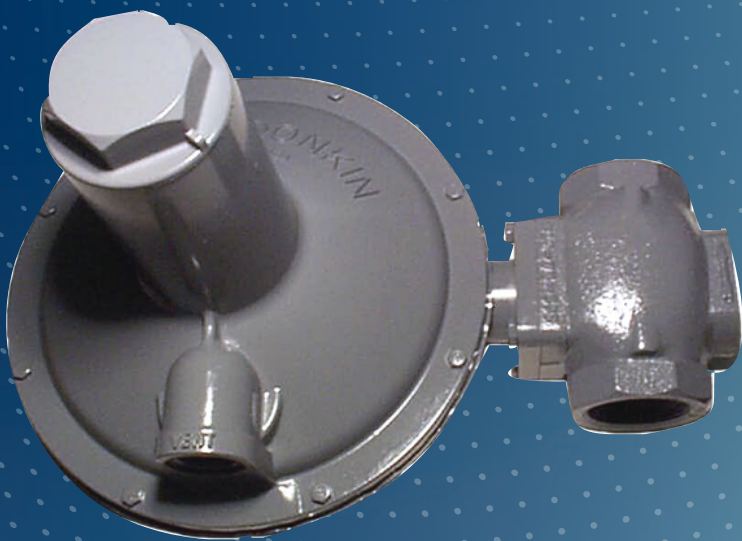

MODEL 274 REGULATOR

Introduction, Characteristics, Constructions, Technical Data

Introduction

- The Model 274 Regulator is a lever operated, spring loaded regulator
- Use with confidence on natural and manufactured gases of non-aggressive nature, including nitrogen, carbon dioxide, propane, butane, etc.
- Versions available for special applications like indoor applications with no requirement for vent-line
- Fixed factor billing model available (PFM) for applications that require accuracy to +/- 1% absolute pressure
- CSA 6.22 Line Pressure Regulator Approved

Characteristics

- Wide inlet pressure range 1-125 psi (0.07-8.6 bar) depending on orifice diameter
- Maximum inlet pressure 150 psi (10.3 bar)
- Maximum allowable operating pressure 125 psi (8.6 bar) depending on orifice diameter
- Lever-operated to accommodate changes in inlet pressure, spring-loaded for increased speed of response
- Various interchangeable orifices for ease of maintenance, customability and increased turndown ratio to accommodate a wide range of flow and pressure requirements
- Outlet pressure range from 6" wc - 6.0 psi (15.0-420 mbar) over 5 spring ranges
- 3 different inlet/outlet thread types (NPT, BSPT, BSPP) in 1¼, 1½, 2" screwed in-line (180°)
- 2" flanged connections (180°) in ANSI150 RF/FF or PN16 RF/FF. Flanged body material available in cast iron, ductile iron or cast steel
- Balance valve version available for increased accuracy and control
- Various internal relief valve assemblies available (full, limited and none)
- 1" threaded vent connection
- Available with internal (I.C.L.) or external (E.C.L.) impulse
- Ease of maintenance due to interchangeable diaphragm casing cartridge
- Various integral safety slam-shut (SSV) models available for pressure/flow shut off protection.
- Custom designed and pre-fabricated regulator meter set assemblies available
- Pilot-loaded version available for higher outlet pressure set points and higher flow capacities

Available Constructions

- 274 R - full internal relief valve
- 274 P - no internal relief valve
- 274 SD - safety diaphragm version (internal vent-limiting device)
- 274LR-OPCO - limited internal relief valve capacity with integral over-pressure slam-shut device
- 274P-OPCO - no internal relief valve capacity with integral over-pressure slam-shut device
- 274SD-OPCO SD - safety diaphragm version with integral over-pressure slam-shut device and internal vent limiting devices (indoor installations only)
- 274LR-309 UPCO/OPCO - limited internal relief valve capacity with integral under and over-pressure slam-shut device
- 274P-309 UPCO/OPCO - no internal relief valve capacity with integral under and over-pressure slam-shut device
- 274SD-309 UPCO/OPCO - safety diaphragm version with integral over and under-pressure slam-shut device and internal vent limiting devices (indoor installations only)
- PFM Version - fixed factor billing or pressure factor metering version for outlet pressure accuracy of +/- 1% absolute pressure
- 274 F - complete with inlet mesh filter
- 274 EFV - complete with excess flow valve
- 274SD-309 t OPCO - safety diaphragm version with integral over-pressure slam-shut device and integral vent limiting device plus thermal trip protection for shut-off at high temperature limit (indoor installations only)
- 274 with stainless steel relief valve assembly for pulse burner applications
- 273PL - pilot-operated version (see Model 273PL Regulator technical bulletin for more specifications)

PRESSURE RATINGS		
Maximum Inlet Pressure	all orifices	150 psi (10.3 bar)
Maximum Allowable Operating Pressure	5mm, 7.5mm, 10.0mm	125 psi (8.6 bar)
	15.0mm	75 psi (5.0 bar)
	20.0mm	60 psi (4.0 bar)
	25.0mm & 30.0mm	15 psi (1.0 bar)
	30.0mm balanced valve	125 psi (8.6 bar)

Temperature Rating

-40° to 60° Celsius
 -40° to 120° Fahrenheit

Weights

- with screwed body - 18 lb. (8.2 kg)
- with cast iron flanged body - 28 lb. (12.75 kg)
- with ductile iron flanged body - 30 lb. (13.6 kg)
- with cast steel flanged body - 36 lb. (16.4 kg)
- with 290 OPCO - add 1.1 lb. (0.5 kg)
- with 309 UPCO/OPCO - add 2.2 lb. (1.0 kg)
- with 309 T-type UPCO/OPCO - add 4.75 lb. (2.2 kg)

MATERIALS OF CONSTRUCTION	
Screwed Body Casting	Cast Iron or Ductile Iron
Flanged Body Casting	Cast Iron, Ductile Iron or Cast Steel
Diaphragm Casings	Die Cast Aluminum
Diaphragm	Molded Nitrile Rubber with Nylon Reinforcing
Valve Head (Seat)	Polyurethane
Diaphragm Plates	Steel
Orifice (regulator without SSV)	Brass
Orifice (regulator with SSV)	Brass or Stainless Steel (t-type)
Vent Screen	Stainless Steel
Fasteners	Steel
Top Cap	Aluminum
Springs	Steel
Lever	Steel
Relief Valve Assembly	Molded Plastic or Stainless Steel (optional)
Valve Extension	Aluminum
O-Rings	Nitrile Rubber

MODEL 274 REGULATOR

Spring Ranges, Relief Valve Ranges, Correction Factors

OUTLET PRESSURE RANGES		
Range (imperial)	Range (metric)	Spring Number (Colour)
6" - 14" wc	15 - 35 mbar	960 (grey)
12" - 22" wc	30 - 56 mbar	961 (yellow)
20" - 40" wc	50 - 100 mbar	962 (brown)
1.0 - 3.0 psi	70 - 140 mbar	963 (orange)
2.0 - 6.0 psi	140 - 420 mbar	964 (blue)

4 Inlet pressure and orifice diameter have a direct effect on the outlet pressure range since the regulator is unbalanced. These outlet pressure spring ranges are approximate.

Note for regulators with SD-type diaphragm assemblies

• due to recompression of the spring by the diaphragm assemblies, the spring ranges can be increased approximately 10-20%.

RELIEF PRESSURE RANGES		
Range (imperial)	Range (metric)	Spring Number (Colour)
12" - 34" wc	30 - 85 mbar	960 (grey)
22" - 50" wc	55 - 125 mbar	961 (yellow)
34" - 68" wc	85 - 170 mbar	962 (brown)
2.0 - 5.0 psi	140 - 350 mbar	963 (orange)
3.0 - 9.0 psi	210 - 630 mbar	964 (blue)

CORRECTION FACTORS FOR OTHER GASES		
Gas Type	Specific Gravity	Correction Factor (CF)
Air	1.00	0.77
Butane	2.01	0.55
Carbon Dioxide (Dry)	1.52	0.63
Carbon Monoxide (Dry)	0.97	0.79
Natural Gas	0.60	1.00
Nitrogen	0.97	0.79
Propane	1.53	0.63
Propane-Air Mix	1.20	0.71

For Other Conversion Factors

$$C_f = \sqrt{\frac{0.6}{\text{SG of Gas}}}$$

MODEL 274 REGULATOR

Dimensional Data, Sectional View, SSV Reset, ECL Connection, Spring Adjustment

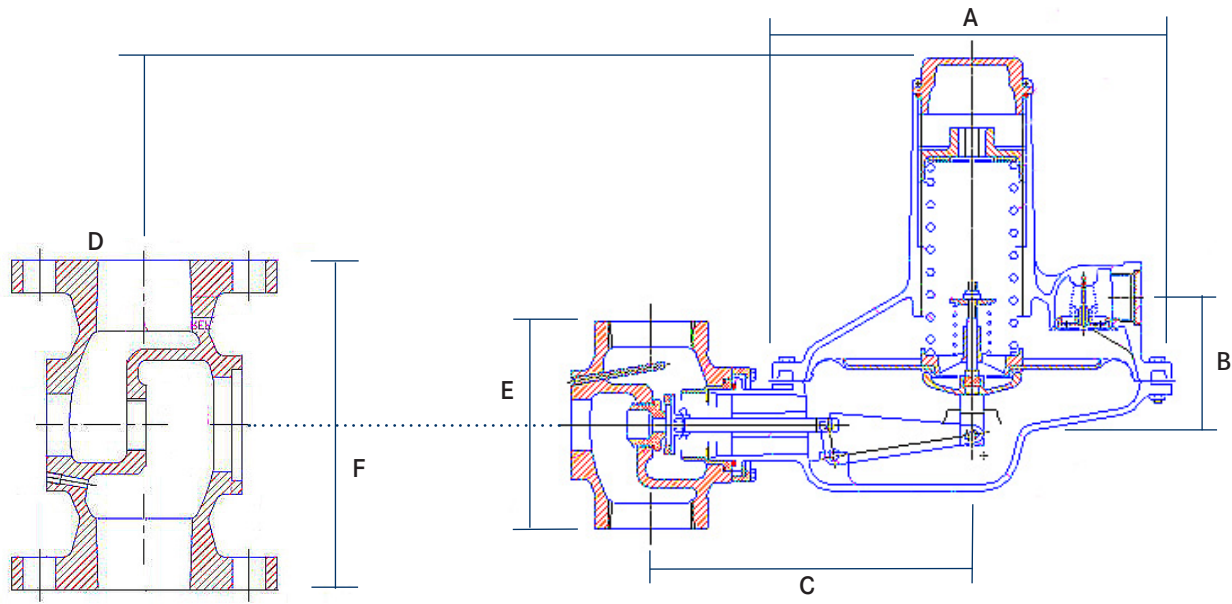

5

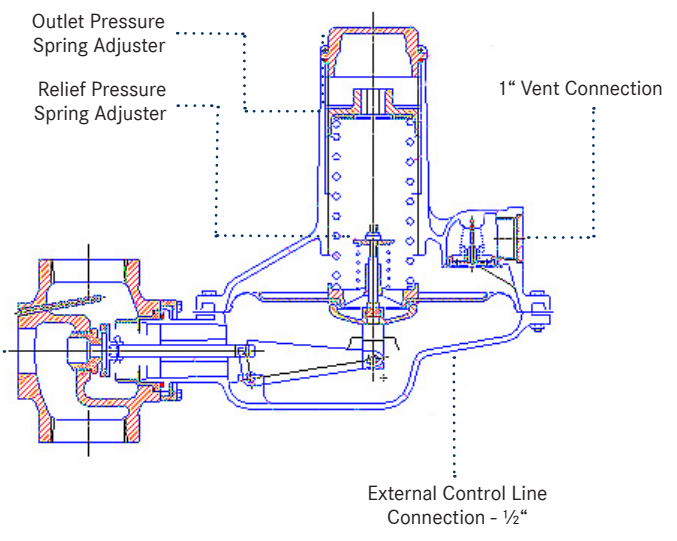
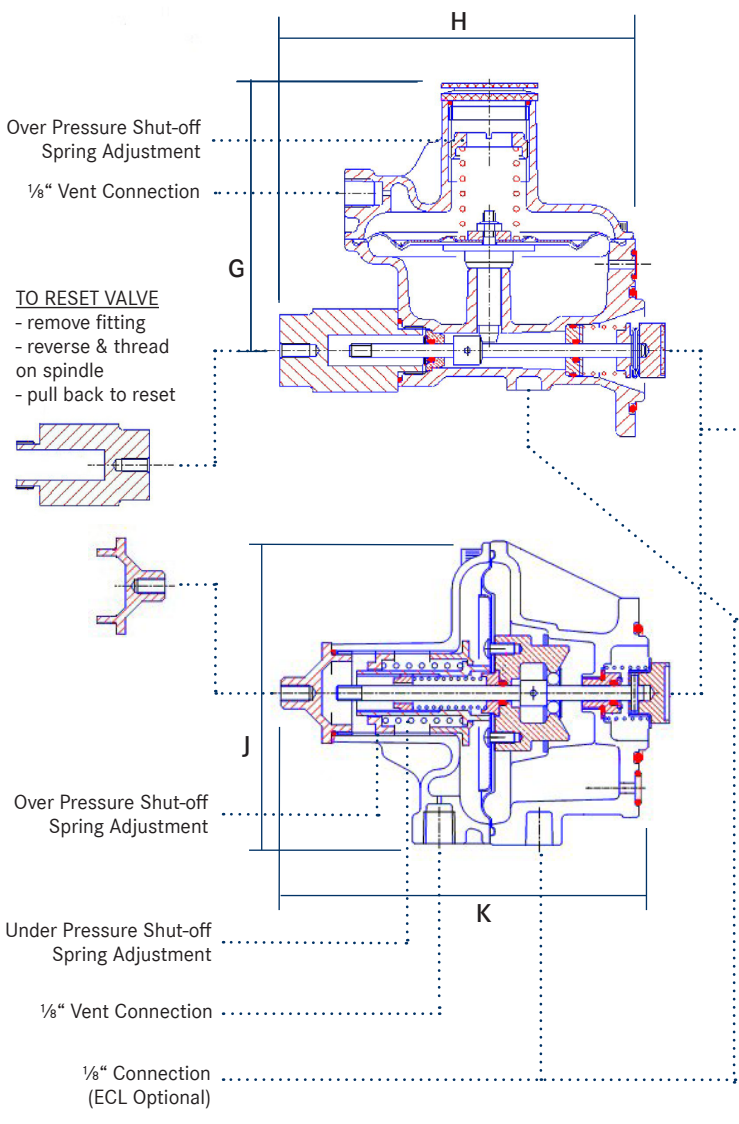

DIMENSIONS									
A	B	C	D	E	F	G	H	J	K
11"	3 1/2"	8 3/4"	10"	5 3/4"	7 1/2"	3 3/4"	3 3/4"	3 3/4"	4 3/4"
279mm	76mm	222mm	254mm	146mm	190mm	95mm	95mm	95mm	121mm

OVERALL LENGTH	
274 (screwed body)	18" (157mm)
274 (flanged body)	20" (508mm)
274-290 (screwed body)	25" (635mm)
274-290 (flanged body)	25" (635mm)
274-309 (screwed body)	27" (686mm)
274-309 (flanged body)	27" (686mm)

MODEL 274 REGULATOR

Orientation, Approvals, Vent-Less Indoor Regulator

Body/Vent Orientation

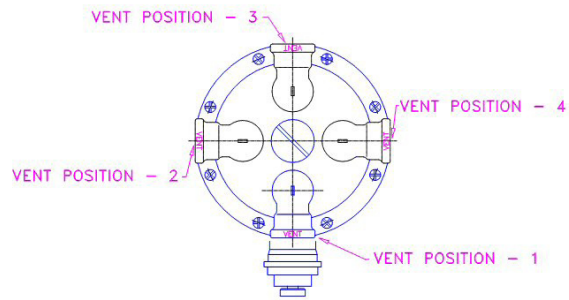

Agency Approvals

- Measurement Canada Approved (P.F.M. applications)
- CSA 6.22 Line Pressure Regulator Approved
- CE Approved

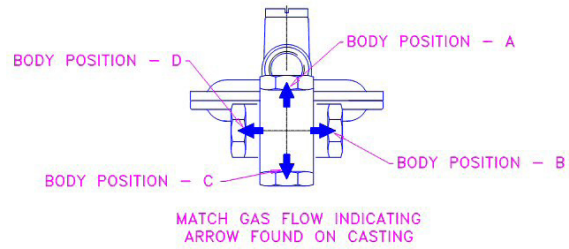

Indoor „Vent-Less“ Regulator - CSA 6.22 Approved

- Regulator assembly incorporates a regulator with integral over-pressure safety slam-shut device (OPCO)
- Regulator does not incorporate an internal relief valve (IRV)
- Both regulator and integral slam-shut device have internal vent-limiting devices to limit the gas expelled from the valve upon diaphragm failure to below 1 ft³/hr (0.0283 m³/hr)
- If there is an over-pressure condition above a pre-determined level downstream of the regulator assembly, the slam-shut device (OPCO) will completely shut-off the gas flow.
- The valve must be manually reset after an over-pressure shut-off condition
- The regulator and slam-shut device have vent connections. These are for atmospheric reference and do not require a vent line connection to the outside
- Vent lines will actually restrict the performance of the regulator
- REFER TO TECHNICAL BOOKLET - CERTIFIED LINE PRESSURE REGULATORS FOR MORE INFORMATION

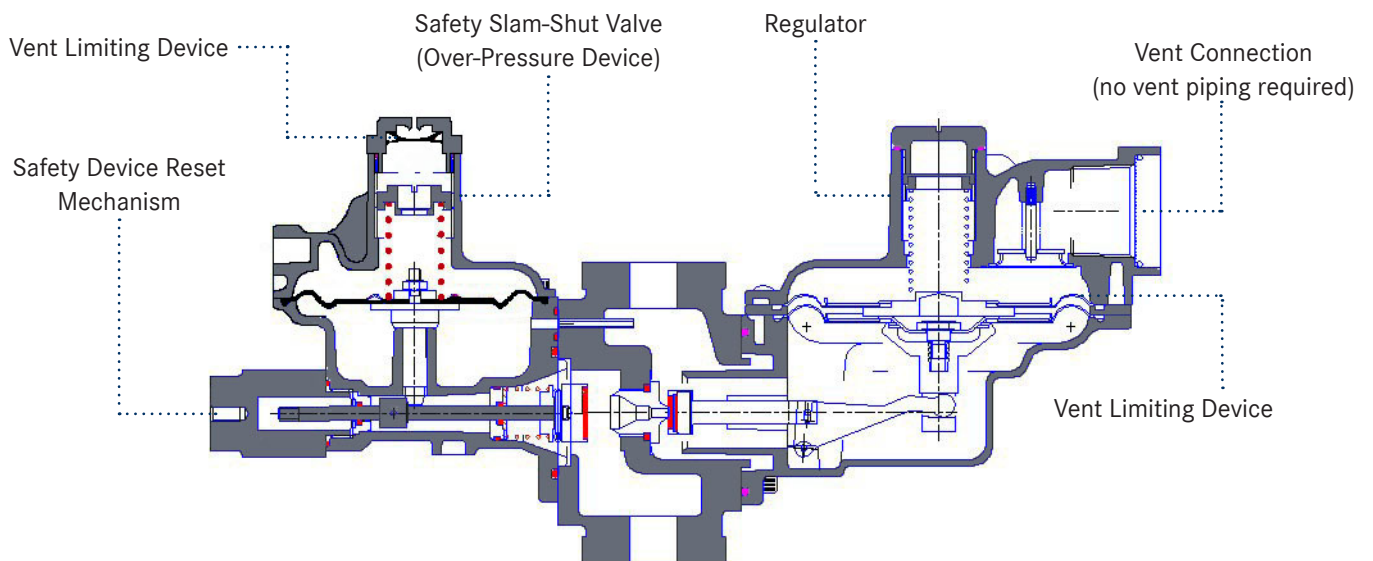

MODEL 274 REGULATOR

Performance Capacities

Spring (Spring Range)	Outlet Pressure	Inlet Pressure		Orifice Diameter											
		psi	bar	5.0mm		7.5mm		10.0mm		15.0mm		20.0mm		30.0mm	
Spring 960 (range 6"-14" wc) (range 15-35 mbar)	SET POINT 7" wc (18 mbar) DROOP/ BOOST 1" wc 2.5 mbar Accuracy Class 20%	0.5	0.035												
		1	0.070	400	(11.3)	800	(22.7)	1000	(28.3)	1500	(42.5)	1750	(49.6)	1700	(48.2)
		2	0.140	550	(15.6)	1100	(31.2)	1450	(41.1)	2200	(62.3)	2500	(70.8)	3300	(93.5)
		5	0.350	900	(24.5)	1750	(49.6)	2500	(70.8)	3500	(99.2)	4200	(119.0)	5500	(155.8)
		10	0.700	1200	(34.0)	2300	(65.2)	4000	(113.3)	5500	(155.8)	14000	(396.6)	13000	(368.3)
		15	1.0	1600	(45.3)	3000	(85.0)	5000	(141.6)	12000	(340.0)	16000	(453.3)	16000	(453.3)
		30	2.0	2200	(62.3)	4700	(133.1)	10000	(283.3)	16000	(453.3)	16000	(453.3)		
		45	3.0	2700	(76.5)	7200	(204.0)	16000	(453.3)	16000	(453.3)	16000	(453.3)		
		60	4.1	3400	(96.3)	10000	(283.3)	16000	(453.3)	16000	(453.3)	16000	(453.3)		
		75	5.2	4200	(119.0)	11000	(311.6)	16000	(453.3)	16000	(453.3)				
		100	7.1	7000	(198.3)	12500	(354.1)	16000	(453.3)						
		125	8.6	9500	(269.1)	16000	(453.3)	16000	(453.3)						

7

Spring (Spring Range)	Outlet Pressure	Inlet Pressure		Orifice Diameter											
		psi	bar	5.0mm		7.5mm		10.0mm		15.0mm		20.0mm		30.0mm	
Spring 960 (range 6"-14" wc) (range 15-35 mbar)	SET POINT 10" wc (18 mbar) DROOP/ BOOST 2" wc 5.0 mbar Accuracy Class 20%	0.5	0.035												
		1	0.070	350	(9.9)	600	(17.0)	800	(22.7)	1100	(31.2)	1600	(45.3)	1650	(46.7)
		2	0.140	500	(14.2)	1000	(28.3)	1350	(38.2)	2000	(56.7)	2300	(65.2)	3000	(85.0)
		5	0.350	800	(22.7)	1600	(45.3)	2300	(65.2)	3200	(90.7)	4000	(113.3)	5400	(153.0)
		10	0.700	1100	(31.2)	2150	(60.9)	3700	(104.8)	5200	(147.3)	14000	(396.6)	12000	(339.9)
		15	1.0	1400	(39.7)	2700	(76.5)	4700	(133.1)	12000	(339.9)	16000	(453.3)	16000	(453.3)
		30	2.0	2100	(59.5)	4400	(124.6)	10000	(283.3)	16000	(453.3)	16000	(453.3)		
		45	3.0	2500	(70.8)	6900	(195.5)	16000	(453.3)	16000	(453.3)	16000	(453.3)		
		60	4.1	3150	(89.2)	9000	(255.0)	16000	(453.3)	16000	(453.3)	16000	(453.3)		
		75	5.2	3800	(107.6)	10000	(283.3)	16000	(453.3)	16000	(453.3)				
		100	7.1	6000	(170.0)	11000	(311.6)	16000	(453.3)						
		125	8.6	8000	(226.6)	15000	(424.9)	16000	(453.3)						

Spring (Spring Range)	Outlet Pressure	Inlet Pressure		Orifice Diameter											
		psi	bar	5.0mm		7.5mm		10.0mm		15.0mm		20.0mm		30.0mm	
Spring 961 (range 12"-22" wc) (range 30-56 mbar)	SET POINT 14" wc (35 mbar) DROOP/ BOOST 3" wc 7.5 mbar Accuracy Class 20%	0.5	0.035												
		1	0.070	350	(9.9)	550	(15.6)	700	(19.8)	1000	(28.3)	1450	(41.1)	1600	(45.3)
		2	0.140	450	(12.7)	900	(25.5)	1100	(31.2)	1750	(49.6)	2200	(62.3)	2800	(79.3)
		5	0.350	850	(24.1)	1500	(42.5)	1850	(52.4)	2650	(75.1)	3200	(90.7)	5200	(147.3)
		10	0.700	1150	(32.6)	2000	(56.7)	3000	(85.0)	4400	(124.6)	12500	(354.1)	12500	(354.1)
		15	1.0	1400	(39.7)	3100	(87.8)	3900	(110.5)	5500	(155.8)	15000	(424.9)	16000	(453.3)
		30	2.0	2000	(56.7)	4100	(116.1)	9000	(255.0)	17000	(481.6)	23000	(651.6)		
		45	3.0	2600	(73.7)	5500	(155.8)	12000	(339.9)	21500	(609.1)	24000	(679.9)		
		60	4.1	3300	(93.5)	8800	(249.3)	14500	(410.8)	21500	(609.1)	24500	(694.1)		
		75	5.2	3700	(104.8)	10500	(297.5)	17500	(495.8)	21500	(609.1)				
		100	7.1	4200	(119.0)	12000	(339.9)	17500	(495.8)						
		125	8.6	5500	(155.8)	15000	(424.9)	17500	(495.8)						

MODEL 274 REGULATOR

Performance Capacities

8

Spring (Spring Range)	Outlet Pressure	Inlet Pressure		Orifice Diameter											
		psi	bar	5.0mm		7.5mm		10.0mm		15.0mm		20.0mm		30.0mm	
Spring 961 (range 12"-22" wc) (range 30-56 mbar)	SET POINT 18" wc (46 mbar)	0.5	0.035												
		1	0.070	350	(9.9)	500	(14.2)	750	(21.2)	1000	(28.3)	1500	(42.5)	1600	(45.3)
		2	0.140	450	(12.7)	850	(24.1)	1000	(28.3)	1700	(48.2)	2200	(62.3)	3000	(85.0)
		5	0.350	850	(24.1)	1450	(41.1)	1800	(51.0)	2500	(70.8)	3000	(85.0)	5200	(147.3)
		10	0.700	1150	(32.6)	2000	(56.7)	3000	(85.0)	4000	(113.3)	12500	(354.1)	13000	(368.3)
		15	1.0	1400	(39.7)	3000	(85.0)	3600	(102.0)	5500	(155.8)	14500	(410.8)	16000	(453.3)
	DROOP/ BOOST 4" wc 10 mbar	30	2.0	2000	(56.7)	4200	(119.0)	8500	(240.8)	17000	(481.6)	22000	(623.2)	ft ³ /hr (m ³ /hr)	
		45	3.0	2550	(72.2)	5500	(155.8)	12000	(339.9)	21500	(609.1)	22500	(637.4)		
		60	4.1	3200	(90.7)	8500	(240.8)	14000	(396.6)	21500	(609.1)	22500	(637.4)		
		75	5.2	3600	(102.0)	10500	(297.5)	16500	(467.4)	21500	(609.1)				
		100	7.1	4000	(113.3)	12500	(354.1)	16500	(467.4)						
		125	8.6	5400	(153.0)	14500	(410.8)	16500	(467.4)						

Spring (Spring Range)	Outlet Pressure	Inlet Pressure		Orifice Diameter											
		psi	bar	5.0mm		7.5mm		10.0mm		15.0mm		20.0mm		30.0mm	
Spring 962 (range 20"-40" wc) (range 50-100 mbar)	SET POINT 28" wc (70 mbar)	2	0.140	400	(11.3)	800	(22.7)	1000	(28.3)	1600	(45.3)	2200	(62.3)	2700	(76.5)
		5	0.350	700	(19.8)	1400	(39.7)	1750	(49.6)	2400	(68.0)	2900	(82.2)	5300	(150.1)
		10	0.700	1100	(31.2)	2000	(56.7)	2600	(73.6)	3600	(102.0)	4800	(136.0)	5500	(155.8)
		15	1.0	1400	(39.7)	2400	(68.0)	3300	(93.5)	4700	(133.1)	6000	(170.0)	16000	(453.3)
	DROOP/ BOOST 6" wc 15 mbar	30	2.0	2200	(62.3)	3700	(104.8)	5500	(155.8)	15000	(424.9)	20000	(566.6)	ft ³ /hr (m ³ /hr)	
		45	3.0	2600	(73.7)	5400	(153.0)	11500	(325.8)	25000	(708.2)	24000	(679.9)		
		60	4.1	3300	(93.5)	9100	(257.8)	14500	(410.8)	26500	(750.7)	26500	(750.7)		
		75	5.2	4000	(113.3)	10500	(297.5)	18000	(509.9)	26500	(750.7)				
		100	7.1	5400	(153.0)	12500	(354.1)	20500	(580.7)						
		125	8.6	7000	(198.3)	15500	(439.1)	24000	(679.9)						

Spring (Spring Range)	Outlet Pressure	Inlet Pressure		Orifice Diameter											
		psi	bar	5.0mm		7.5mm		10.0mm		15.0mm		20.0mm		30.0mm	
Spring 963 (range 1.0-3.0 psi) (range 70-210 mbar)	SET POINT 2.0 psi (140 mbar)	5	0.350	600	(17.0)	1100	(31.2)	1450	(41.1)	2200	(62.3)	2600	(73.7)	3500	(99.1)
		10	0.700	1050	(29.7)	1800	(51.0)	2000	(56.7)	2900	(82.2)	3000	(85.0)	4600	(130.1)
		15	1.0	1300	(36.8)	2250	(63.7)	2550	(72.2)	4400	(124.6)	4750	(134.6)	13000	(368.3)
	DROOP/ BOOST 11" wc 28 mbar	30	2.0	2000	(56.7)	3800	(107.6)	4200	(119.0)	9200	(260.6)	12500	(354.1)	ft ³ /hr (m ³ /hr)	
		45	3.0	2600	(73.7)	5000	(141.6)	5700	(161.5)	16000	(453.3)	22000	(623.2)		
		60	4.1	3250	(92.1)	5700	(161.5)	12500	(354.1)	22500	(637.4)	24000	(680.0)		
		75	5.2	3800	(107.6)	10000	(283.3)	16000	(453.3)	22500	(637.4)				
		100	7.1	4200	(119.0)	12500	(354.1)	18500	(524.1)						
125	8.6	5300	(150.1)	15000	(424.9)	21500	(609.1)								

MODEL 274 REGULATOR

Performance Capacities

Spring (Spring Range)	Outlet Pressure	Inlet Pressure		Orifice Diameter											
		psi	bar	5.0mm		7.5mm		10.0mm		15.0mm		20.0mm		30.0mm	
Spring 964 (range 2.0-6.0 psi) (range 140-420 mbar)	SET POINT 5.0 psi (350 mbar)	10	0.700	750	(21.2)	1550	(43.9)	1800	(51.0)	2400	(68.0)	3100	(87.8)	3600	(102.0)
		15	1.0	1000	(28.3)	2150	(60.9)	2200	(62.3)	3000	(85.0)	3800	(107.6)	4800	(136.0)
		30	2.0	2000	(56.7)	2900	(82.2)	3600	(102.0)	5000	(141.6)	8500	(240.8)	ft ³ /hr (m ³ /hr)	
	DROOP/ BOOST 1.0 psi 70 mbar	45	3.0	2500	(70.8)	4000	(113.3)	4800	(136.0)	8000	(226.6)	11500	(325.8)		
		60	4.1	3000	(85.0)	5000	(141.6)	6300	(178.5)	12000	(339.9)	16500	(467.4)		
		75	5.2	3500	(99.2)	7300	(206.8)	8500	(240.8)	16500	(467.4)				
	Accuracy Class 20%	100	7.1	4000	(113.3)	9000	(255.0)	11000	(311.6)						
		125	8.6	4500	(127.5)	12000	(339.9)	15500	(439.1)						

Pressure Factor Metering (+/- 1% Absolute Pressure)
Measurement Canada Approved - AG-0539

Spring (Spring Range)	Outlet Pressure	Inlet Pressure		Orifice Diameter			
		psi	bar	7.5mm		10.0mm	
Spring 963 (range 1.0-3.0 psi) (range 70-210 mbar)	SET POINT 2.0 psi (140 mbar)	10	0.7	385	(10.9)	195	(5.5)
		20	1.4	710	(20.1)	965	(27.3)
		30	2.0	1355	(38.4)	1225	(34.7)
		40	2.7	1805	(51.1)	2515	(71.2)
	Accuracy Class +/-1% ABS PFM	50	3.4	2900	(82.2)	1740	(49.3)
		60	4.1	3160	(89.5)	6065	(171.8)
		70	4.8	4835	(137.0)	6450	(182.7)
		80	5.4	6125	(173.5)	7355	(208.3)
		90	6.1	7870	(222.9)	8255	(233.9)

Inlet Pressure Set Point
40 psig (2.7 bar)

ft³/hr
(m³/hr)

Spring (Spring Range)	Outlet Pressure	Inlet Pressure		Orifice Diameter			
		psi	bar	7.5mm		10.0mm	
Spring 964 (range 2.0-6.0 psi) (range 140-420 mbar)	SET POINT 5.0 psi (350 mbar)	10	0.7	195	(5.5)	195	(5.5)
		20	1.4	320	(9.1)	255	(7.2)
		30	2.0	710	(20.1)	710	(20.1)
		40	2.7	710	(20.1)	775	(22.0)
	Accuracy Class +/-1% ABS PFM	50	3.4	1095	(31.0)	1095	(31.0)
		60	4.1	1290	(36.5)	1225	(34.7)
		70	4.8	1485	(42.1)	2645	(74.9)
		80	5.4	2000	(56.7)	3610	(102.3)
		90	6.1	2385	(67.6)	4320	(122.4)

Inlet Pressure Set Point
40 psig (2.7 bar)

ft³/hr
(m³/hr)

MODEL 274 REGULATOR

Internal to External Impulse Conversion (E.C.L.)

External Control Line (E.C.L.)

- The standard regulator is supplied as internally impusled or internal control line (I.C.L.) unless specified
- Sensing outlet pressure via an external control line enables the regulator to respond more accurately to the downstream system.
- Additionally, the standard regulator is supplied with both bosses drilled and tapped on the underside of the diaphragm casing. These bosses will be plugged with a removeable brass fitting.

- To modify to E.C.L., remove the 4 bolts that secure the diaphragm casing to the regulator body. Remove the throat extension and o-rings. Ensure that the o-rings and the throat extension are kept away from debris
- Remove the valve seat by taking out the cotter pin that secures it to the valve extension.
- Secure the throat seal down the valve extension, ensuring that it bottoms out against the diaphragm casing. Secure with the circlip.

- Replace the valve seat and new cotter pin. Replace throat extension and o-rings.
- Bolt body back to the diaphragm casing with the 4 original bolts.
- Remove one of the brass fittings from the bottom of the diaphragm casing.
- Connect ½" compression fitting and external control line to this boss.
- The sensing point at the termination of the control line should be a minimum of 5 times the nominal pipe diameter at the outlet of the regulator.

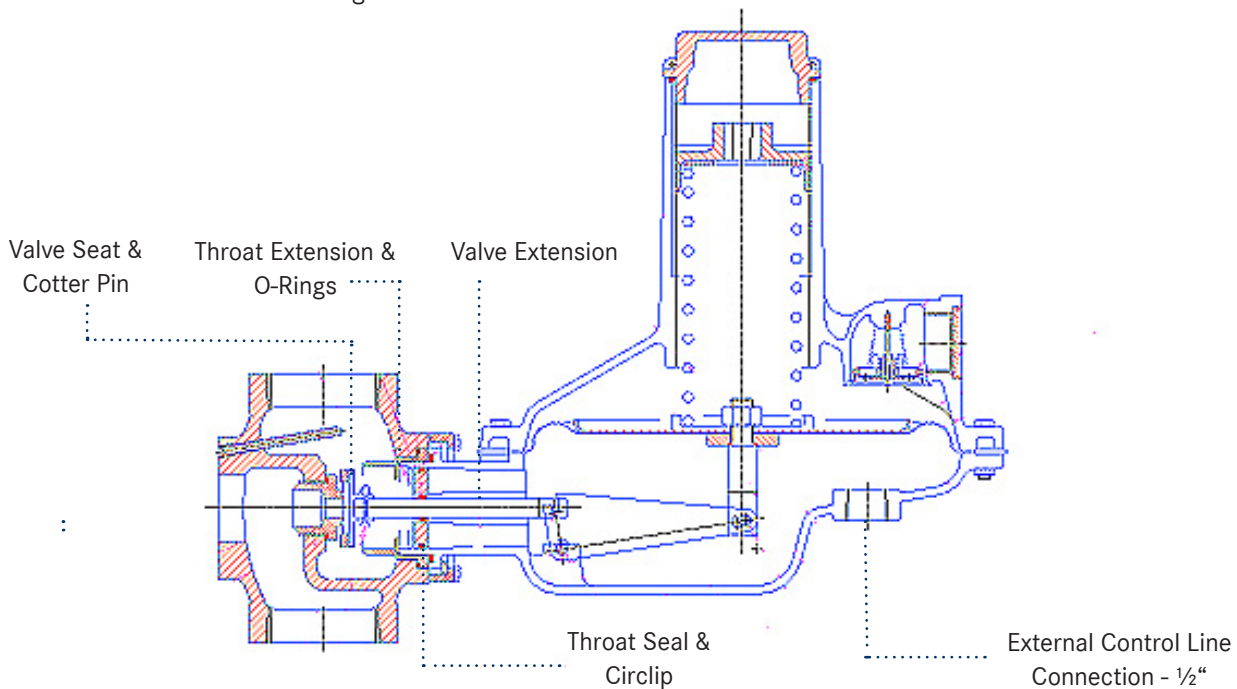

VARIOUS SPARE PARTS	
Description	Part Number
Throat Seal Assembly	MN-005
Circlip	5005-0175
Valve Seat (polyurethane)	MM/001
Cotter Pin	2mm x 25mm
Spares Kit for 274 P	CSK 1876
Spares Kit for 274 R	CSK 1886
Spares Kit for 274 LR	CSK 1896
Spares Kit for 274 SD	CSK 1868

PARTS REQUIRED FOR I.C.L. TO E.C.L. CONVERSION		
Bullet	Description	Part Number
1	Throat Seal Assembly (includes:)	MN-005
	- Seal Disc	202/LG/004
	- O-ring	BS/USA 128
	- O-ring	BD/USA 110
2	Retaining Clip	5005-0175
3	Cotter Pin for Valve Seat	2mm x 25mm

MODEL 274 REGULATOR

Part Numbering System

RMG 274 R 1 H N C I X 3 B X K F

INTERNAL RELIEF	
R	full relief
P	no relief
L	limited relief
S	safety diaphragm

OPCO TYPE	
1	290-OPCO
2	309LP OPCO
3	309LP UPCO/OPCO
A	309LP t OPCO
B	309LP t UPCO/OPCO
E	290 t OPCO
F	Excess Flow Valve

CONNECTIONS SIZE	
H	1¼" x 1¼"
I	1¼" x 1½"
J	1¼" x 2"
K	1½" x 1½"
L	1½" x 2"
M	2" x 2"

CONNECTION TYPE	
N	NPT
B	BSPT
P	BSPP

MATERIAL	
C	Cast Iron
D	Ductile Iron
S	Cast Steel

IMPULSE	
I	Internal
E	External

OPTIONAL FEATURES	
U	Union Connection
I	Test Point on Inlet
O	Test Point on Outlet
E	Casting Engraving
S	External Spring Adjuster
B	Test Point on both Inlet & Outlet
P	P.F.M. Pressure Factor Metering
F	Inlet Filter Strainer
Z	Blanking Plate
V	Excess Flow Valve
R	Stainless Steel Relief Valve Assembly

BODY/VENT ORIENTATION	
A1	A
A2	B
A3	C
A4	D
B1	E
B2	F
B3	G
B4	H
C1	I
C2	J
C3	K
C4	L
D1	M
D2	N
D3	O
D4	P

ORIFICE DIAMETER	
5.0mm	A
7.5mm	B
10.0mm	C
15.0mm	F
20.0mm	G
25.0mm	H
30.0mm	I

UPCO SPRING	
1138	A
638	B

OPCO SPRING	
861	A
868	B
1254	C
1171	F
1172	G
1173	H
1174	I
1175	J

MAIN SPRING	
960	0
961	1
962	2
963	3
964	4
995	5



RMG is your worldwide partner for gas control equipment, ranging from exploration to consumer supply. The comprehensive range of RMG products and systems provides you with a total solution for all your gas control and measurement needs

Modern manufacturing techniques combined with our expertise and specialist knowledge in the design and build of gas control equipment, including fully automated stations has earned RMG a worldwide reputation for supply of safe, accurate and reliable equipment.

WWW.RMG.COM

GERMANY

RMG REGEL + MESSTECHNIK GMBH
Osterholzstrasse 45
K-34123 Kassel
Tel +49 (0) 561.5007.0
Fax +49 (0) 561.5007.107

WÄGA WÄRME-GASTECHNIK GMBH
Osterholzstrasse 45
D-34123 Kassel
Tel +49 (0) 561.50707.0
Fax +49 (0) 561.5007.207

RMG MESSTECHNIK GMBH
Otto-Hahn-Strasse 5
D-35510 Butzbach
Tel +49 (0) 6033.897.0
Fax +49 (0) 6033.897.130
Works Ebersberg
- Software Development -
Anzinger Straße 14
D-85560 Ebersberg
Tel +49 (0) 8092.20.97.0
Fax +49 (0) 8092.20.97.10

RMG-GASELAN REGEL + MESSTECHNIK GMBH
Julius-Pintsch-Ring 3
D-15517 Fürstenwalde
Tel +49 (0) 3361.356.0
Fax +49 (0) 3361.356.836

ENGLAND

BRYAN DONKIN RMG GAS CONTROLS LIMITED
Enterprise Drive, Holmewood
Chesterfield S42 5UZ
England
Tel +44 (0) 1246.501.501
Fax +44 (0) 1246.501.500

CANADA

BRYAN DONKIN RMG CANADA LIMITED
50 Clarke Street South
Woodstock, Ontario
Canada N4S 0A8
Tel +1 (0) 519.539.8531
Fax +1 (0) 519.537.3339

POLAND

GAZOMET SP. Z O.O
ul. Sarnowska 2
63-900 Rawicz
Poland
Tel +48 (0) 65.546.2401
Fax +48 (0) 65.546.2408

UNITED STATES OF AMERICA

MERCURY INSTRUMENTS INC, USA
3940 Virginia Avenue
Cincinnati, Ohio
U.S.A. 45227
Tel +1 (0) 513.272.1111
Fax +1 (0) 513.272.0211